

## CRBF50X70E-70X100E-A1E Espositori a cavalletto

## SCHEDA TECNICA



### STRUTTURA



MATERIALE: alluminio/lamiera



FINITURA: silver



INDOOR/OUTDOOR

### GRAFICA



GRAFICA INTERCAMBIABILE



BIFACCIALE

Cavalletti bifacciali Premium in alluminio estruso con applicate n. 2 cornici a scatto ad angolo tondo frame 32 mm. Fondo in lamiera grigia e fogli di protezione frontale in PVC antiriflesso.

# CRBF50X70E-70X100E-A1E

## Espositori a cavalletto

### SCHEDA TECNICA

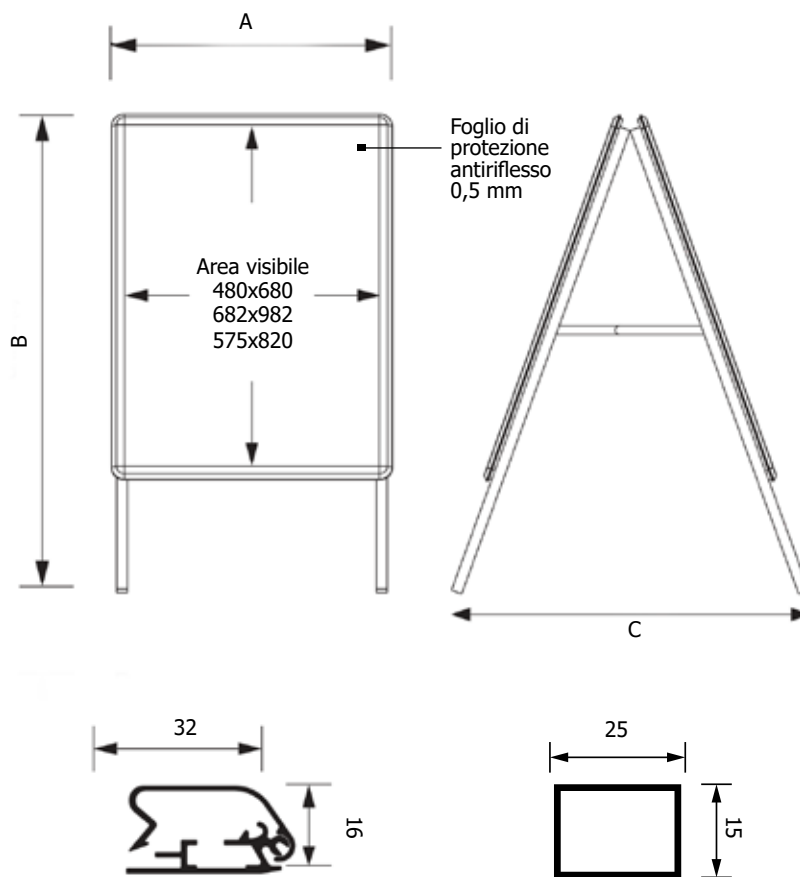

#### SISTEMA APERTURA A SCATTO

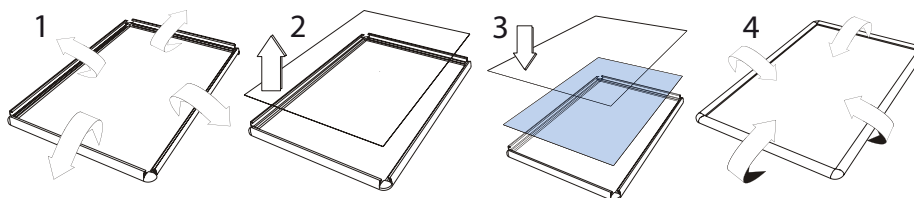

#### DIMENSIONI PRODOTTO (mm)

Codice	F.to poster	F.to visibile	Dim. totale (AxBxC)	Cod. EAN
<b>CRBF50X70E</b>	500x700	480x680	543x905x840	0768855794900
<b>CRBF70X100E</b>	700x1000	682x982	743x1176x840	0768855793163
<b>CRBFA1E</b>	594x841	575x820	637x1015x755	0768855793170

#### MISURE IMBALLO (mm/kg)

Codice	Dim. imballo	Peso art.	Peso art. e imballo
<b>CRBF50X70E</b>	630x1080x85	6,8	7,9
<b>CRBF70X100E</b>	800x1390x85	10,79	12,74
<b>CRBFA1E</b>	720x1180x85	7,10	8